

Drum Handling



The Caldwell Group • 800-628-4263 • www.caldwellinc.com

Lif-Truc™ Section
2011-2013 Master Catalog

Model FDL - Fork Lift Drum Lifter/Rotator

The Caldwell Lifter/Rotator unit is designed for use with a lift truck in areas where an overhead hoist is not available. The drum is secured to the carrier above the level of the forks thus it may be used at the full height of the truck. With the chain wheel, the lift truck driver may rotate the drum from the cab of the truck (10' long drop chain). This unit will handle all standard 55 gallon metal drums.

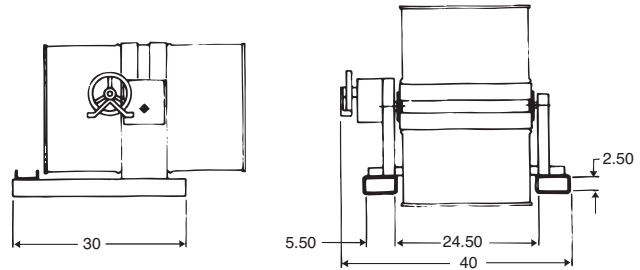

NOTE: Dimensions shown in inches.

SPECIFICATIONS

Model Number	Rated Capacity (lbs.)		Weight (lbs.)
	Full Drum	Half Drum	
FDL-20-55	2000	1000	310

NOTE: The standard model FDL is for lifting drums containing free flowing liquids. Contact factory for drums containing other contents.

WARNING

Capacity of lift truck and attachment combination may be less than capacity shown on attachment. Consult lift truck manufacturer.

Model FDD - Fork Lift Drum Lifter/Dumper

Designed to easily and economically lift, travel with, and dump drums into acceptable type containers. Pressure applied to the drum base against rim of container will tilt drum to preferred angle of emptying. Drum is secured to the lifter by a load binder. This unit will handle all standard 55 gallon metal drums.

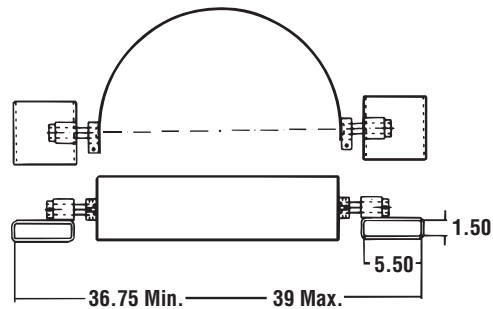

NOTE: Dimensions shown in inches.

SPECIFICATIONS

Model Number	Rated Capacity (lbs.)		Weight (lbs.)
	Full Drum	Half Drum	
FDD-10-55	1000	500	38