

# Booms



## Model ROB - Reach Over Fork Lift Boom

Use the Reach Over Boom when an extension boom is required and clearance is a factor.



**QUICKSHIP PROGRAM**

### PRODUCT FEATURES:

- Multiple hook positions.
- Telescoping boom.
- Restraining chain with grab hook.
- Swivel hooks with hook latches.

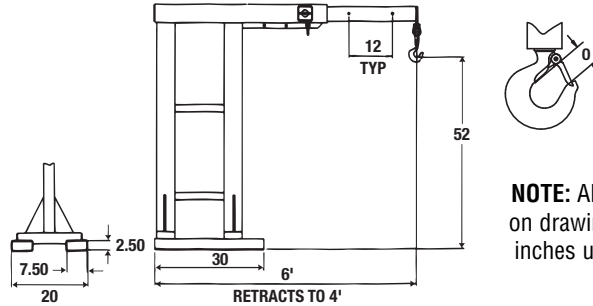

**NOTE:** All dimensions on drawings shown in inches unless stated.

### SPECIFICATIONS

Model Number	Maximum Capacity (lbs.)	Hook Opening O (in.)	Weight (lbs.)
<b>ROB-40</b>	4000	1.09	470
Capacity At Hook Position (lbs.)			
4'	4000		
5'	3500		
6'	1800		

### WARNING

Capacity of lift truck and attachment combination may be less than capacity shown on attachment. Consult lift truck manufacturer.

## Model FCJ - Carriage Jib Fork Lift Boom

Use the Carriage Jib Boom attachment when fork obstruction is undesirable.



### PRODUCT FEATURES:

- Horizontally adjusting, 15° left or right of center, pivot boom.
- Designed for ITA Class II fork carriages.
- Multiple hook positions.
- Swivel hooks with hook latches.

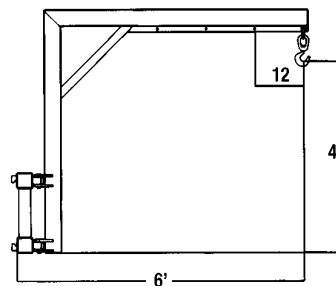

**NOTE:** All dimensions on drawings shown in inches unless stated.

### SPECIFICATIONS

Model Number	Maximum Capacity (lbs.)	Hook Opening O (in.)	Weight (lbs.)
<b>FCJ-40</b>	4000	1.09	310
Capacity At Hook Position (lbs.)			
3'	4000		
4'	3000		
5'	2300		
6'	1800		